

PoliLam

PoliLam



www.polilam.com

One-Stop Decorative
Surfaces Provider

FIBER 



Class A Fire Retardant Material

PoliLam Fiber® is decorative wall panel made with a melamine impregnated decorative layer and special composite glass fiber noncombustible core material at high temperature and high pressure.

This product has excellent flame retardancy, won't expand, and can effectively slow down combustion and flame diffusion. Our advanced production process of PoliLam Fiber® gives this product numerous characteristics including antibacterial, heat resistance, waterproof, abrasion resistance, impact resistance, corrosion resistance, and easy clean surface.

In addition to excellent physical performances, PoliLam Fiber® is in line with PoliLam's design process where we collaborate with renowned European design companies to jointly design and develop our collection. We use advanced digital scanning technology to replicate natural materials by reprocessing and redesigning real natural material. We combine technology with nature to create surface decorative panels centered on environmental protection and design. With a rich color system and surface texture, for designers to choose from. Exceeding industry demands for space customization.



Fire Retardant

The laminate is molded at one time at high temperature and high pressure, and a new generation of Class A fire retardant materials, providing people with a safe building environment.



Anti-Bacterial

Silver ion technology is added to inhibit the growth of mold and bacteria on the surface, keeping the finish tidy and clean for a long time.



Anti-Bacterial

The laminate supports a variety of cutting and installation methods (glue can be directly attached to flat surfaces such as tiles and cement without keel backing), which greatly saves installation time and cost. Convenient construction and easy maintenance.



Environmentally Friendly

This green building material has passed various environmental certifications. It does not contain asbestos or harmful radioactive elements and is harmless to the human body.



Design Enhancement

PoliLam Fiber® has a variety of colors, wood grain, stone grain, solid color and delicate texture selection, which enhances the competitiveness of the overall environment and customer experience and can meet different customization needs of customers.



Water and moisture resistance

The physical characteristics of glass fiber core material make PoliLam Fiber® have better waterproof and impermeable properties.

Universal characteristics



Scratch and Abrasion Resistant



Very Low Levels of Swelling Properties



Dimensionally Stable and Rigid



High Temperature Resistance



Diverse and Flexible Design



Easy to Cut and Make



Easy Clean



Resistant to Cigarette Burns



Lightweight



Modular And Quick Installation

CERTIFICATION AND QUALIFICATION

As a company we have completed ISO9001, ISO14001, ISO18001 quality management classifications as well as environmental and occupational health system classifications. Continuously reaching GREENLABEL and GREENGUARD environmental system classifications; FSC forest certification concerned with environmental systems and more.

A Declaration on Sustainable Development :

PoliLam has always pursued environmental protection when it comes to their production process and finished products. Applying energy management, waste management, environmental management, transportation and raw material supply channel management to sustainable development practices and fulfilling social responsibilities. Meanwhile, we are committed to improving the efficiency of the use of resources so as to achieve the long-term goal of protecting the Earth's environment and sustainable use of resources.



COLOR. TEXTURE. CULTURE.

PoliLam regards sustainable development as a business virtue and value, strictly abides by it, and always will.

PoliLam's raw material suppliers have undergone strict screening and auditing.

We have established long-term and stable cooperative relationships with high-quality suppliers in Europe, from the introduction of virgin paper, color paper printing to steel plate embossing.

PoliLam's design and development team collaborates with renowned European design companies to jointly design and develop.

Create more original designs (including wood grain, stone grain, and special decors) for global clients.

In addition, we use advanced digital scanning technology to replicate natural materials, And reprocess and redesign some rare tree or rock textures to obtain ideal patterns.

We aspire to be a 'replica of nature' and constantly seek inspiration from life.

Integrate rationality and sensibility, combine technology with nature, and create surface decorative panels centered on environmental protection and design.

PoliLam always adheres to the concept of design first, innovation first, and product first,

Persist in making good products, designing well, and pursuing excellence.



Color is crucial in interior design as it affects our mood, attitude, and perception.



PoliLam incorporates texture while replicating the natural appearance, Touch is one of the five senses of human beings, affecting every detail of daily life; Steel plate development enables us to achieve all of this



Culture influences everything, and PoliLam's culture pools the world's culture into our design through the power of technology

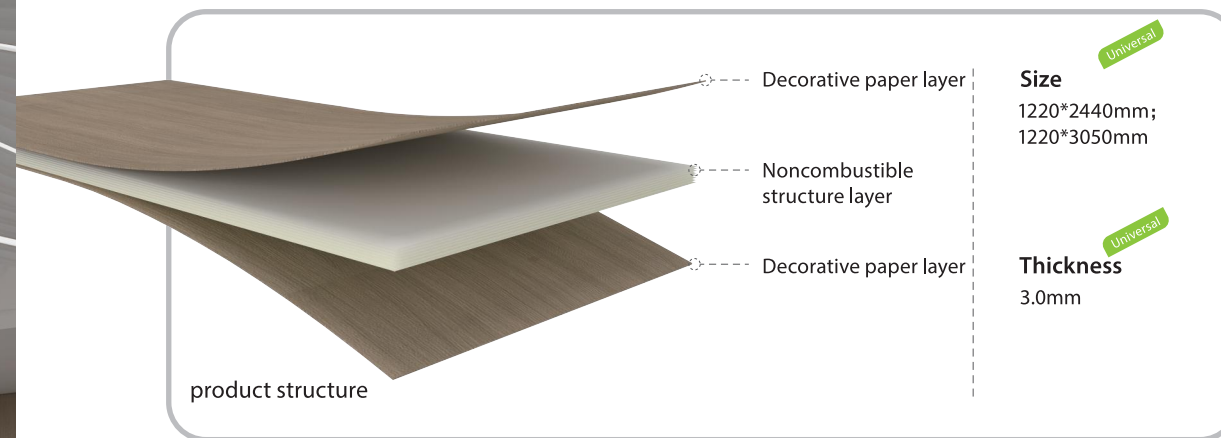

TECHNICAL PARAMETERS

Performance Test Results

Test Items	Test Standard	Standard Value	Unit	Conclusion
Thickness	GB/T7911-2013	3.0mm±0.2mm	mm	Qualified
Fire Rating (combustion performance level)	GB8624-2012	Class A2 Noncombustible	Class	Qualified
Dimensional stability	GB/T7911-2013	Portrait (T) 0.4%; Andscape (L) 0.6%	%	Qualified
Resistance to large ball impact	GB/T7911-2013	Maximum depression diameter ≤ 10	mm	Qualified
Scratch resistance	GB/T7911-2013	Not below 3	Level	Qualified
Pollution resistance	GB/T7911-2013	Not below 4	Level	Qualified
Abrasion resistance	GB/T7911-2013	Not below 3	Level	Qualified
Color fastness to light	GB/T7911-2013	4-5	Level	Qualified
Crack resistance	GB/T7911-2013	Not below 4	Level	Qualified
Dry heat resistance	GB/T7911-2013	Not below 3 Not below 4	Appearance, Level Others, Level	Qualified
Damp-heat resistance	GB/T7911-2013	Not below 5	Level	Qualified
Water vapor resistance	GB/T7911-2013	Not below 4	Level	Qualified
Smoke burning resistance	GB/T7911-2013	Not below 3	Level	Qualified

In order to meet A2 combustion performance (GB8624-2012), it must be ensured that the product is used in conjunction with the inorganic non-combustible version above 4 mm.

APPLICATION AREAS

PoliLam Fiber® is a widely used decorative fireproof wall panel. Suitable for wall and ceiling decoration of various types of public spaces, healthcare, education, hotels, and commercial buildings. It can also be used for interior decoration of spaces such as basements, corridors, factories, laboratories, etc. Additionally, it can be used in space areas such as public partitions, bathrooms, splash shields, etc.

EDUCATION

Dormitory, Classroom, Multimedia room,
Corridor, Auditorium, Bathroom

/

RESTAURANTS, SUPERMARKETS AND RETAIL

Counter, Half-wall baffle, Preparation area

/

OFFICE

Lounge, Negotiation room,
Reception area, Front desk

/

MEDICAL

Nurse station, Foyer, Waiting room,
Ward, Laboratory, Operating room

/

AIRPORTS, PUBLIC TRANSPORT

Wall panels, Waiting halls, VIP rooms

/

OTHER

Elevators, Entertainment vehicles, Stairwells



The image shown here is indicative only. Please refer to the actual product.

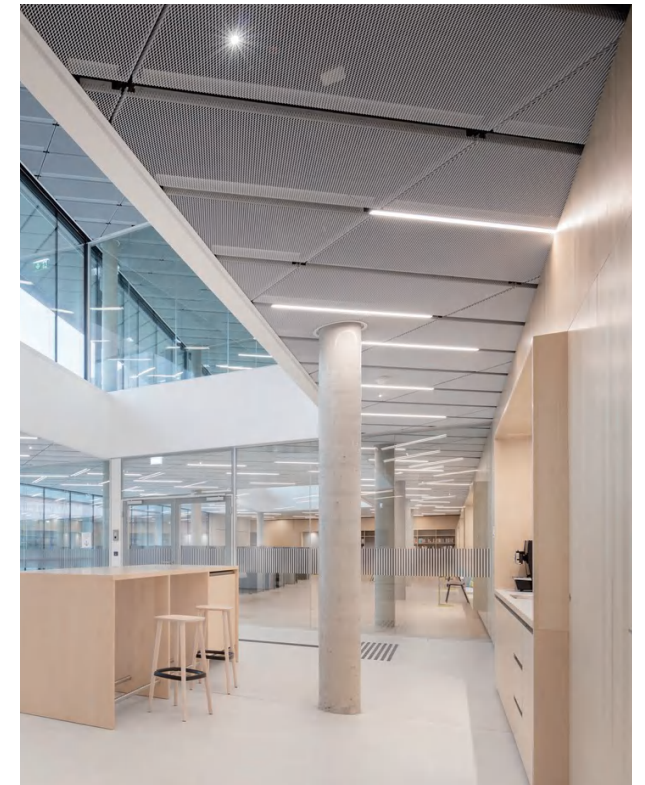

APPLICATION AREAS ---SCHOOLS



**APPLICATION
AREAS---HOTELS**

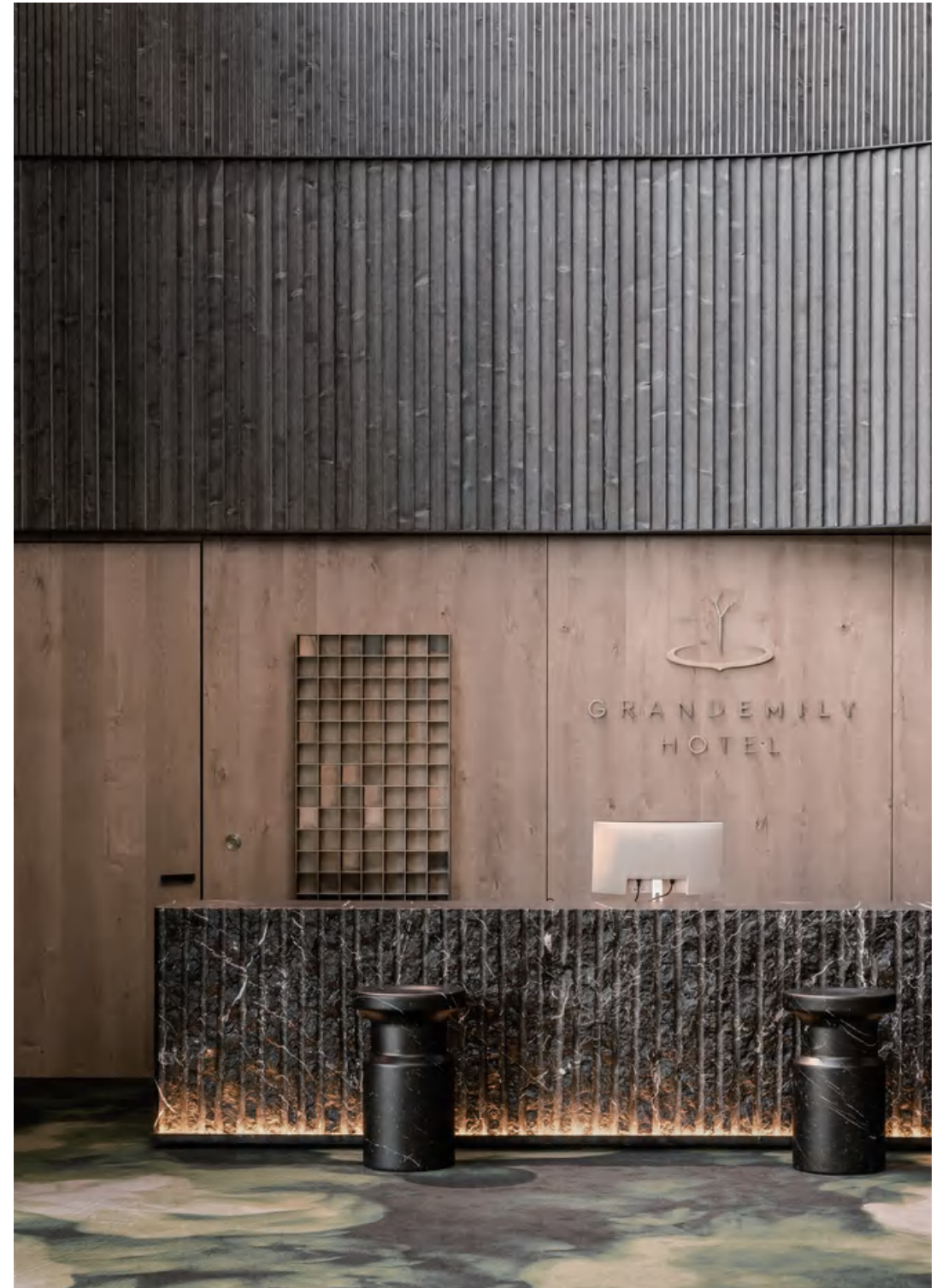

The image shown here is indicative only. Please refer to the actual product.



**APPLICATION
AREAS---MALLS**

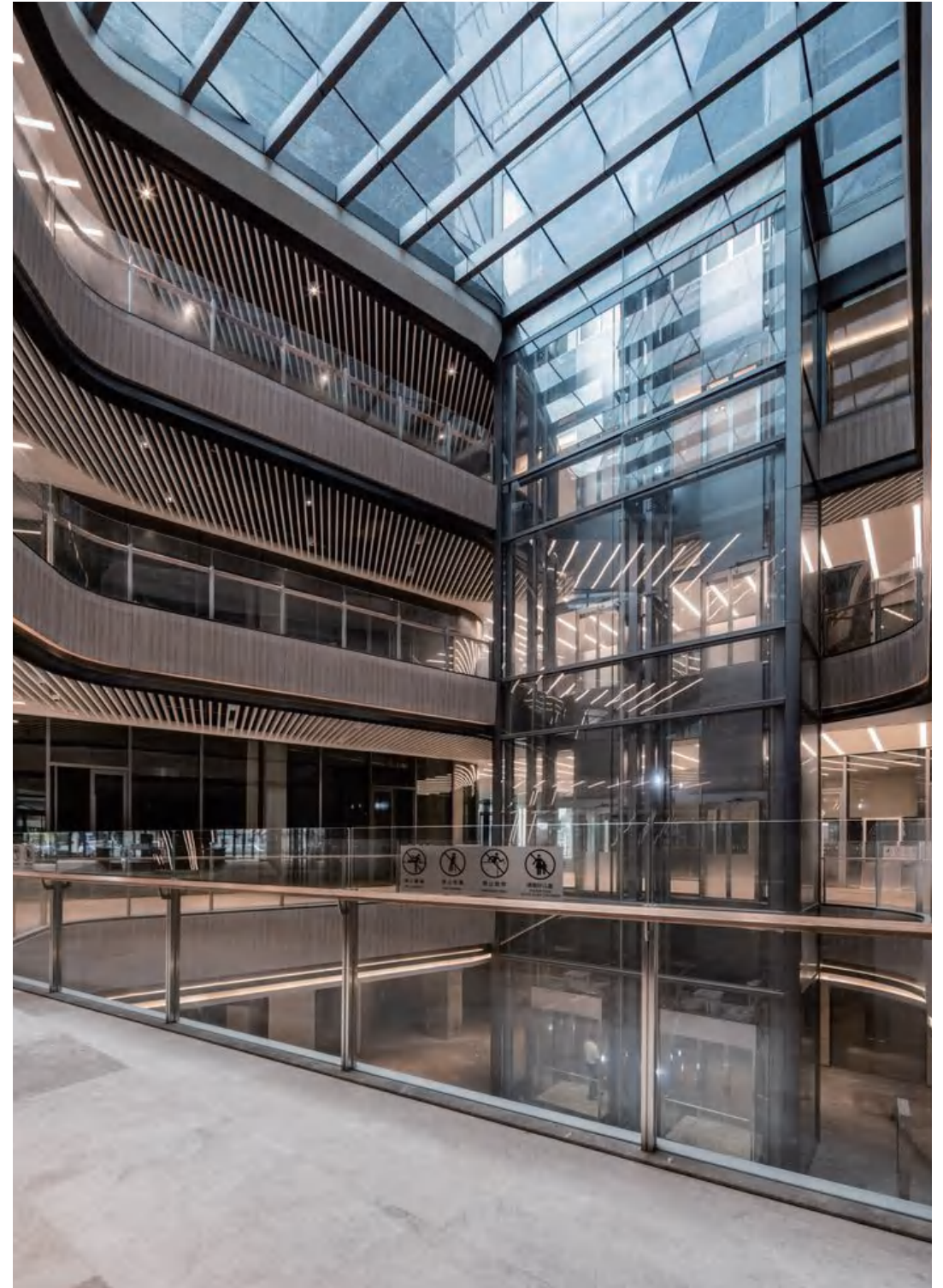

The image shown here is indicative only. Please refer to the actual product.



The image shown here is indicative only. Please refer to the actual product.

APPLICATION AREAS---HOSPITALS



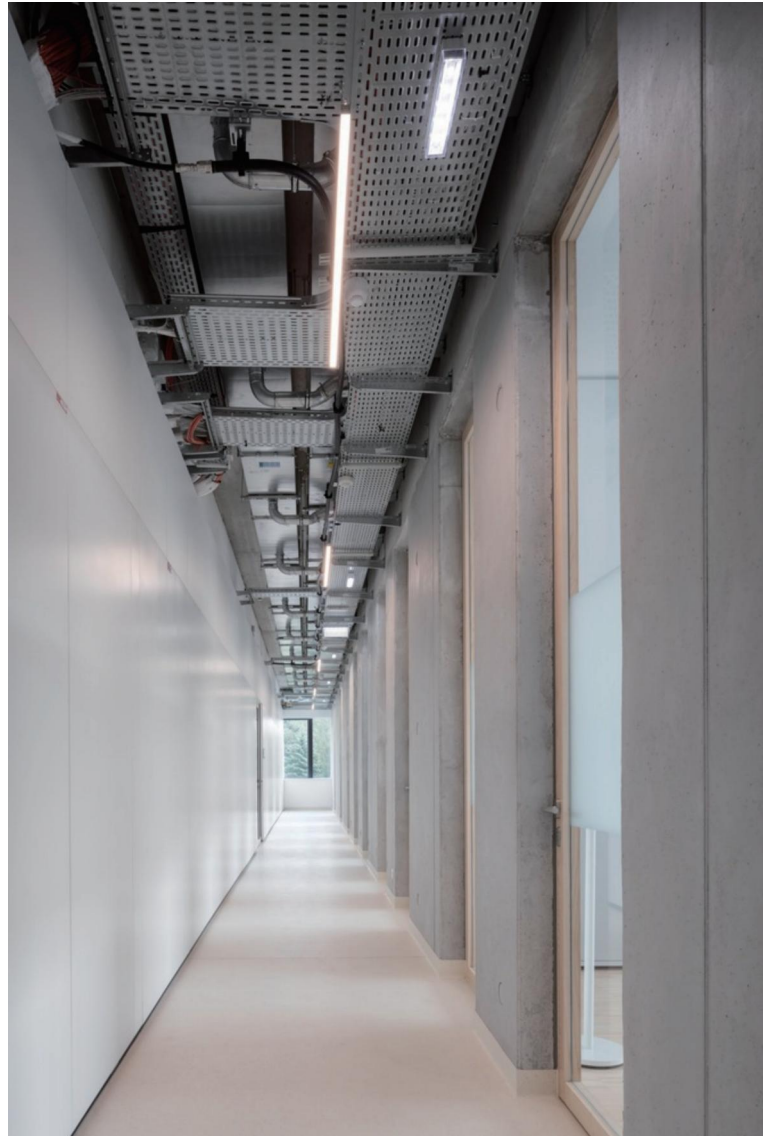

The image shown here is indicative only. Please refer to the actual product.



APPLICATION AREAS---LABS



APPLICATION AREAS---VIP ROOMS



MAINTENANCE GUIDE

STORAGE

- 01 PoliLam Fiber® should be stored indoors in a cool and dry place, avoiding direct sunlight (recommended suitable indoor environment is: room temperature of 24 degrees Celsius, relative humidity of about 45%). Each sheet should be kept clean. Stacked horizontally and neatly on pallets larger than Fiber® boards, with a single stack height of less than 2.4m.
- 02 PoliLam Fiber® should be stored indoors in a cool and dry place, avoiding direct sunlight (recommended suitable indoor environment is: room temperature of 24 degrees Celsius, relative humidity of about 45%). Each sheet should be kept clean. Stacked horizontally and neatly on pallets larger than Fiber® boards, with a single stack height of less than 2.4m.
- 03 PoliLam Fiber® should be stored indoors in a cool and dry place, avoiding direct sunlight (recommended suitable indoor environment is: room temperature of 24 degrees Celsius, relative humidity of about 45%). Each sheet should be kept clean. Stacked horizontally and neatly on pallets larger than Fiber® boards, with a single stack height of less than 2.4m.

TRANSPORTATION AND HANDLING

- 01 During transportation, the pallet must be sufficient to support the load and must not bend or tilt. At the same time, try to use an outer packaging box for protection, and wrap the four corners with protective gear to avoid damage to the edges and corners.
- 02 Fiber® requires two or more people to carry. After the board is lifted horizontally, it should be lifted horizontally and vertically to prevent the board from breaking.
- 03 Pay attention to edge protection during transportation to avoid collisions; Do not drag the board to prevent surface damage.

CUTTING AND SLOTTING

- 01 Fiber® board itself is relatively hard, so ordinary woodworking saws cannot cut it. It is necessary to use a stone cutting machine to cut the board, or a diamond grinding and slicing (brazing) marble machine can be used for cutting.
- 02 Fiber® boards need to be slotted on the side using a professional slotting machine. If manual grooving is required, a marble machine equipped with diamond grinding slices (brazed sheets) must be used to make short grooves on the side.
- 03 When cutting and slotting, it is necessary to pay attention to the correct use and size control of mechanical tools to avoid problems such as edge bursts and cracks.

DRILLING AND TRIMMING

- 01 Special drill bits must be used for the hole opening of PoliLam Fiber® boards.
- 02 To avoid damage to the outlet surface, the drill bit speed and pressure should gradually decrease.
- 03 Place a splint or small wooden block below the drilling point to prevent damage to the outlet.
- 04 To avoid cracking caused by concentrated force, sharp corners should be avoided during drilling. It is recommended to retain a minimum bending radius of 3mm for all internal corners, while smoothing other edges and corners.
- 05 After cutting, the rough edges of the board can be manually polished and smoothed. After polishing, waxing can be used to beautify the board edges and isolate air.

PRESERVATION

- 01 General pollution can be cleaned with a regular damp cloth.
- 02 Mild stains can be cleaned with warm water and neutral soap on the surface.
- 03 Stubborn stains need to be cleaned with a high concentration cleaner or wiped with alcohol.
- 04 For particularly dirty and uneven surfaces of noncombustible boards, nylon soft brushes can be used for cleaning.
- 05 After cleaning and brushing, use a soft dry cloth to wipe.
- 06 Do not use polishing agents with abrasives such as steel brushes to clean, as they may scratch the surface of the board.
- 07 Do not use sharp hard objects to scratch the surface of the board.
- 08 Do not place excessively hot objects directly on the surface of the board.
- 09 Do not use cleaning agents that contain grinding or non-neutral substances.

SPECIAL STAIN TREATMENT

- 01 Printing mud and markings: wet cloth or other tools can be used to wipe and eliminate.
- 02 Pencil marks: can be wiped away with water, rags, and erasers.
- 03 Brush or trademark marks: can be wiped away using methanol alcohol and acetone.
- 04 Paint residue: wipe it with acetone or banana oil or rosin water.
- 05 Strong adhesive residue: can be wiped away with toluene solvent.
- 06 06 White glue residue: can be wiped away with warm water containing 10% ethanol.

DO NOT CONTACT THE FOLLOWING SOLVENTS WITH THE SURFACE OF THE BOARD



Hydrogen peroxide



Bleaching powder



≥2% Alkaline solution



Fabric dye



Berry juice



Sodium hypochlorite



Silver protein



Potassium permanganate



Sodium bisulfate



1% Iodine solution



Gentian violet



≥1% Silver nitrate



Mineral acid
hydrochloric acid
sulfuric acid
or nitric acid

Please Note:

If the use of cleaning agents, chemical solvents, or other maintenance methods by users leads to abnormal use of the board or other usage problems, PoliLam cannot be held responsible.

INSTALLATION METHOD

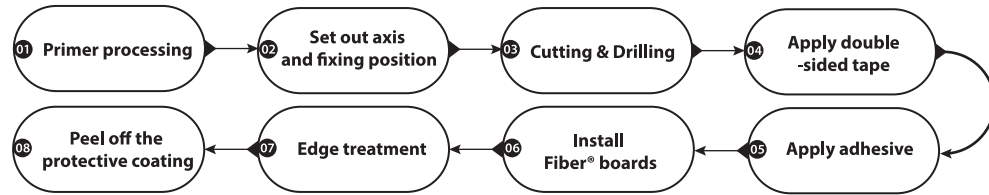

01 Primer Processing

If the substrate is render, it should be applied with construction glue interface agent.

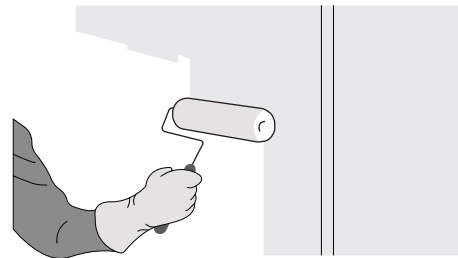

02 Set out axis and fixing position

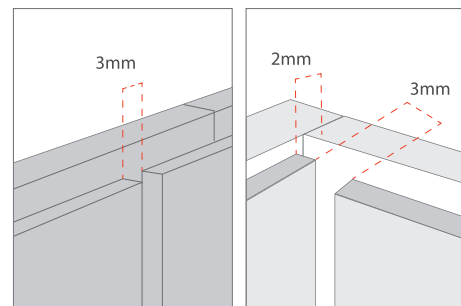

When adjusting the axis, ensure that the board seams are staggered from the substrate seams. Always remain a gap of 3 mm between the PoliLam FIBER Boards.

03 Cutting & Drilling

Use a guiding rule to ensure that the cut is straight and the front side is in the feed direction (there is protective film on the front side). Use a fine-toothed hand saw or electric saw with 10-12 teeth per mm. Or use a masonry cutting disc. Note: It is recommended to use a jigsaw specifically for laminated board cutting.

The edges can be smoothed with a file, sandpaper or plane.

It is recommended to drill slowly and support the board with a base so as to avoid cracks behind the board.

Be sure to wear appropriate safety equipment, such as dust masks, eyes and hearing protection devices and gloves.

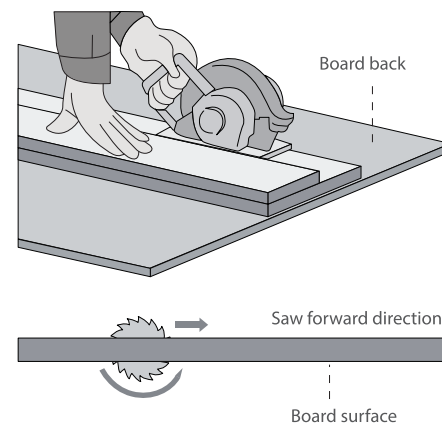

04 Apply double-sided tape

Place the double-sided tape 30 mm from the edge of the front fender and attach the tape to the edge of the tape.

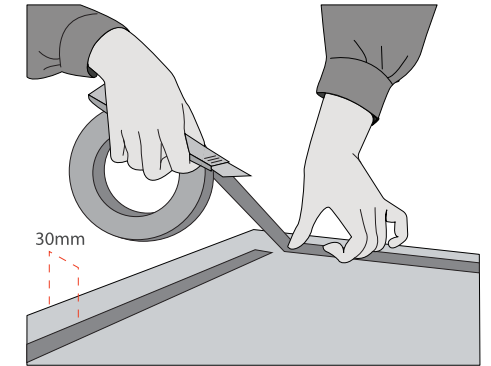

05 Apply adhesive

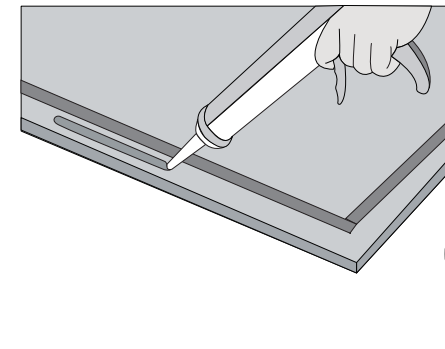

Apply adhesive to the board in a 4 mm width, or at least 3 mm thicker than the tape.

Adhesive application illustration

General condition Apply straight lines to the edges

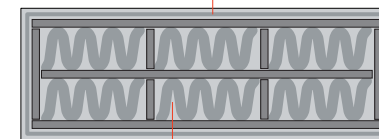

Apply wave shapes to the interior

Cutting Apply straight lines to the edges

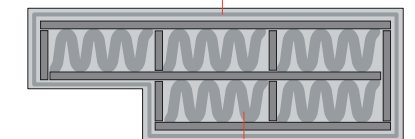

Apply wave shapes to the interior

Drilling holes on the board

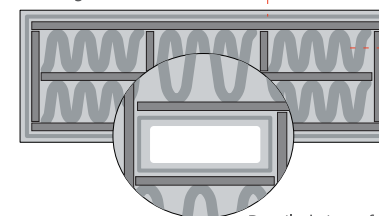

Detailed view of the drilling part

Apply straight lines to the edges

Apply wave shapes to the interior

Note

- Back side of Fiber® board
- Double-sided tape
- Adhesive

06 Install PoliLam FIBER Boards

Place the board over the entire surface to ensure that there are no cavities under the board and that there is sufficient adhesion between the board and the substrate.



07 Edge treatment - Edge strip or adhesive application

1. Aluminum alloy or plastic strip
(Leave a 2 mm gap at the edge of the board inside the strip.)

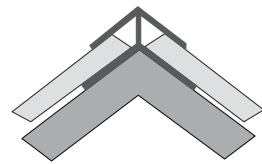

Outside corner

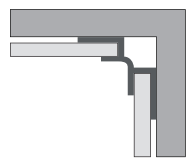

Inside corner



Jointer



End-cap

2. Sealant jointing method

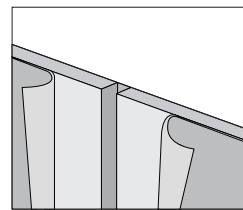

Remove the protective film from the edge of the board.

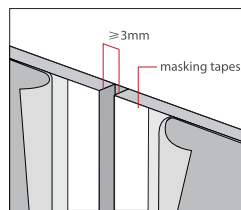

Leave a gap of more than 3 mm between boards, attach masking tapes to the gap and fill with a sealant.

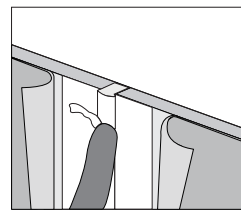

Scrape off excess sealant immediately by a scraper.

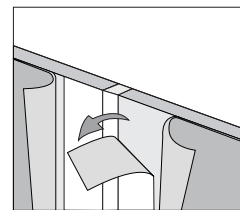

Remove the masking tapes from the gap.

08 Peel off the protective coating

After curing for more than 2 days, please remove the protective film on the surface.

*Construction precautions

- Please use fine sandpaper wrapped with a splint to lightly grind the cutting surface and remove any burrs.
- When sealing the joint, gently remove the burrs from the uncut edges.

INSTALLATION PREPARATION

01 Site Preparation

Use a ruler and plumb line to ensure that the wall is straight and vertical during installation. The walls should be clean, dry, dust-free, and free of grease. And all protrusions such as nails should be removed. Pre-check the squareness of each board and wall, as in some cases it may be necessary to trim or plane the edge of the board prior to installation.

02 Recommended Materials

Cement Fiber Board	Calcium Silicate Board	Render
Recommended minimum thickness ≥8mm, Medium density 1.2-1.5g/cm ³	Recommended thickness ≥9mm	Recommended Moistur Content ≤ 4.5%, Bond Strength ≥1.0N/mm ² , Flatness >2mm

Remove any loose or flaky particles, dust and grease from the surface to ensure the adhesion strength of the nail-free or structural adhesives. Concrete/mortar plastering/magnesia board and other porous substrates shall be sealed with multiple layers of building glue interface agent. Follow the manufacturer's recommendations for application and drying time.

03 Fabrication Accessories



Silicone Sealant

Please choose a silicone sealant that is suitable for use on calcium silicate board, cement board and non-flammable board. Do also make sure that the silicone sealant is suitable to be used in bathrooms, kitchens and other high humidity environments. Please use antifungal silicone sealant.



Adhesive

Please choose an adhesive that is suitable for use on calcium silicate board, cement board and non-flammable board.



Double-sided Tape

For optimal bonding effect, please use a double coated clear polypropylene tapes with acrylic adhesive.

PoliLam

PoliLam Certifications:



Singapore Green Label



EN 45545-2:2013 + A1 Fire Protection
on Railway Vehicles
EN 438-2:2016 + A1 2018



ISO 22196 Anti-Bacterial Test Report



NEMA LD 3-2004 Characteristics
Anti-Bacterial Test Report



GREENGUARD



GREENGUARD GOLD



Instagram
PoliLam



Pinterest
OfficialPoliLam



Facebook
PoliLam



E-mail
sales@polilam.com

www.polilam.com